

2 Band (Bass and Treble) 9 volt or 18 volt Preamp/Tone control

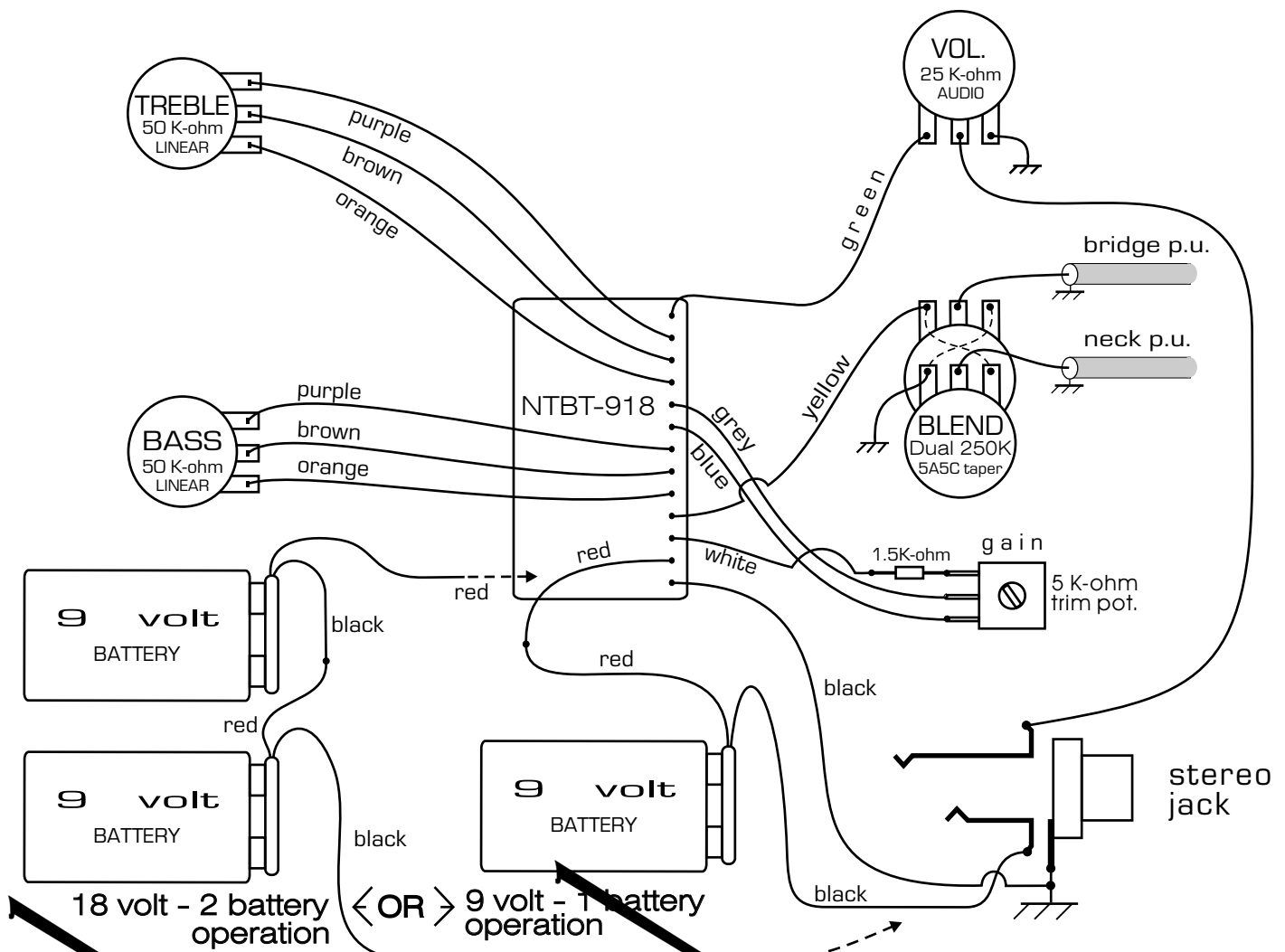

The NTBT-918 is a tone control preamp with fully independent Bass and Treble controls with very low noise and wide boost/cut range. It is 2/3 the size of a 9v battery.

The sound is very clear and transparent. Distortion is well below 0.001%. This preamp can be used with either 1 - 9 volt battery (9 volt operation or 2 - 9 volt batteries (18 volt operation which yields 6 dB extra headroom.

In 9 volt operation the NTBT-918 uses approximately 750 microamperes of current from 1 - 9 volt battery. This means 1 month of continuous duty or more than 6 months of average usage.

In 18 volt operation the NTBT-918 uses approximately 1000 microamperes of current from 2 - 9 volt batteries. This means more than 3 weeks of continuous duty or more than 4 months of average usage.

DO NOT USE MORE THAN 18 volt SUPPLY VOLTAGE OR EXTERNAL POWER SUPPLIES!

NEW Alpha (a) OR Noble (S) BLEND POTENTIOMETER WIRING

both of these new potentiometers have "silver" colored solderable plating
 both brands have C-A tapers (C=left hand audio - A=right hand audio
 wiring is the same for 25 K-ohm and 250 K-ohm pots.

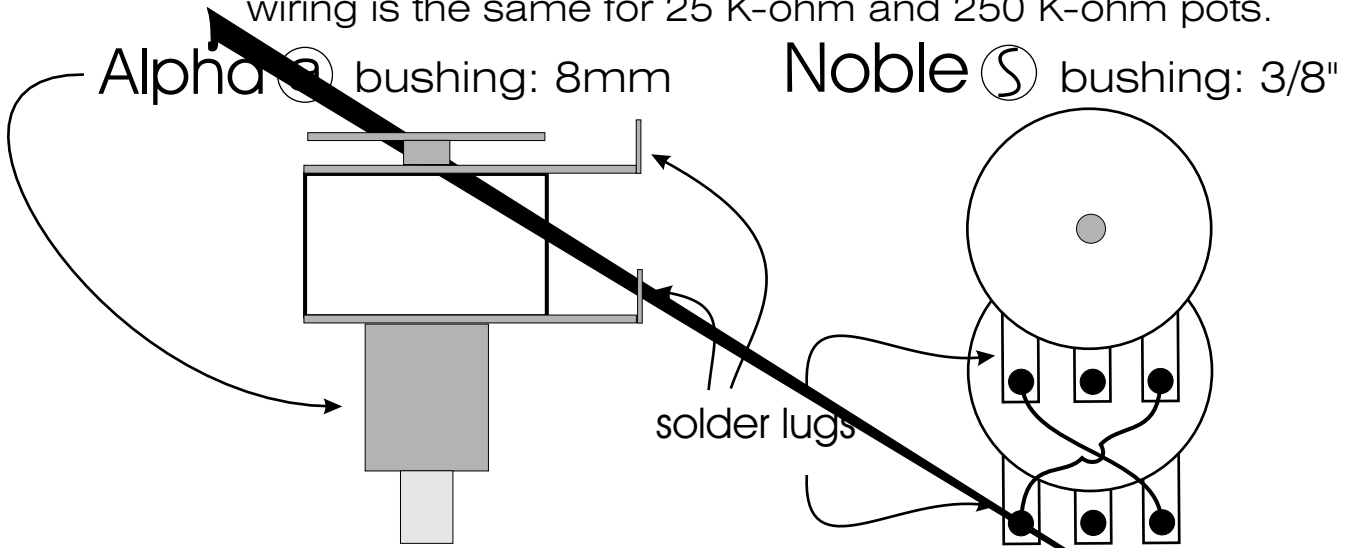

Blend pot wiring viewed from the inside of the control cavity (pot. shaft down)

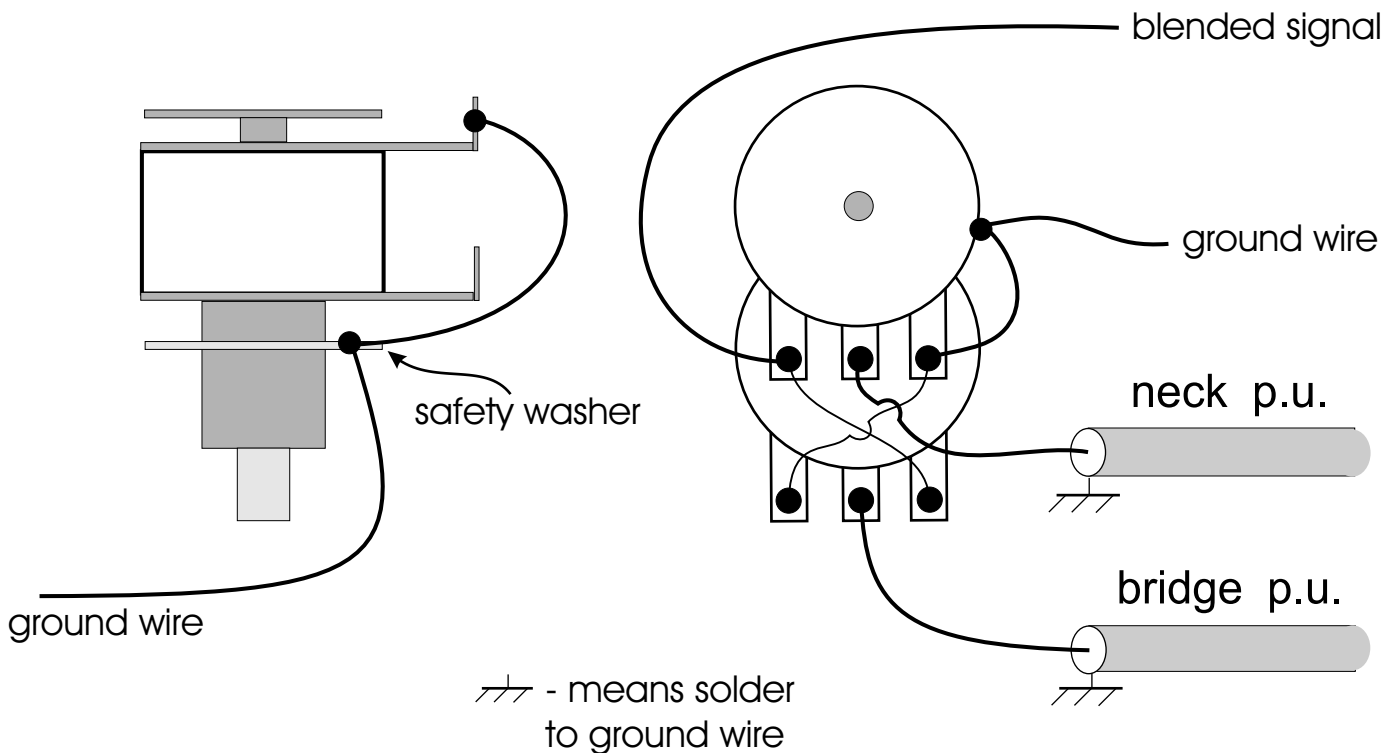

DO NOT OVERHEAT WHEN SOLDERING GROUND WIRES OR ANYTHING ELSE TO THE SIDE OF THESE BLEND POTS